

DFA-R SERIES

Digital Force Gauge

The CHATILLON® DFA-R Series features a dedicated remote loadcell with force measurement accuracy of $\pm 0.15\%$ of full scale ± 1 LSC. All models feature RS232 serial data communications and an internal sampling rate of 10,000Hz. The DFA-R Series is ideal for critical applications where capturing peak readings is required. Other features include the ability to store up to 1000 test readings in up to 99 different user-defined batches. The gauge features programmable high and low setpoints, pushbutton calibration and an analogue output for graphing the force curve. An easy-to-use operator interface lets users perform gauge configuration using the keypad and intelligent prompts and menus from the instrument's high resolution LCD display. Gauges come with accessories, battery charger and protective carrying case.

FEATURES

- Dedicated Remote Loadcell
 - Capacities up to 1000 lbf (5 kN)
- Simple Pushbutton Operation
- Rugged All-Metal Housing
- 10,000Hz Sampling Rate
- Memory: 1000 Readings in 99 Batches
- RS232 Serial Data Communications
- Overload Capacity- 110% of Rated Capacity
- Hand-held or Test Stand Applications

SPECIFICATIONS

Accuracy:	$\pm 0.15\%$ of Full Scale ± 1 LSC
Selectable Units:	oz, g, lb, kg, N
Overload Capacity:	110% of rated capacity
Display:	LCD, 4-1/2 characters
Sampling:	10,000Hz
Outputs:	RS232, Mitutoyo
Power:	AC Adapter, NiCd Battery Pack
Accessories:	Carrying Case, Attachments Extension Rod, Battery Charger
Weight:	2 lbs (0.9 kg)
Warranty:	1 Years



SPECIFICATION
SS-FM-3214-0801
August 2001



Pharmaceuticals



Electronics



Medical Device

INTERNET

www.ametek.com
www.chatillon.com
www.lloyd-instruments.co.uk

AMETEK and CHATILLON are registered trademarks of AMETEK, Inc.
LLOYD INSTRUMENTS is a trademark of AMETEK, Inc.

EASY-TO-USE INTERFACE

DFA Series Gauges put a powerful INTEL® microprocessor in your palm, allowing you to collect up to 1,000 reviewable data readings in memory, then download them via the gauge's RS-232 serial data communications. You follow a simple hierarchy of menu displays to filter data and configure gauge settings, including data transmission. You may even calibrate and test the gauge automatically. The gauges modular architecture allows you to evolve as technology evolves. Using a personal computer, you may download new features and functionality as they are introduced.

FUNCTION keys at each of the four corners of display work with menus to select options, as well as to go to "downstream" menus.

NORMAL DISPLAY starts up after the gauge is turned on. F1 key toggles between the standard force measurement setting or settings which capture peak tension or compression force. Indicators below shows portion of battery charge remaining, time remaining until auto shutdown, and whether the high or low force levels are being exceeded. F4 key allows you to toggle display reading between pounds, kilograms, and Newtons, or ounces, grams, and Newtons.

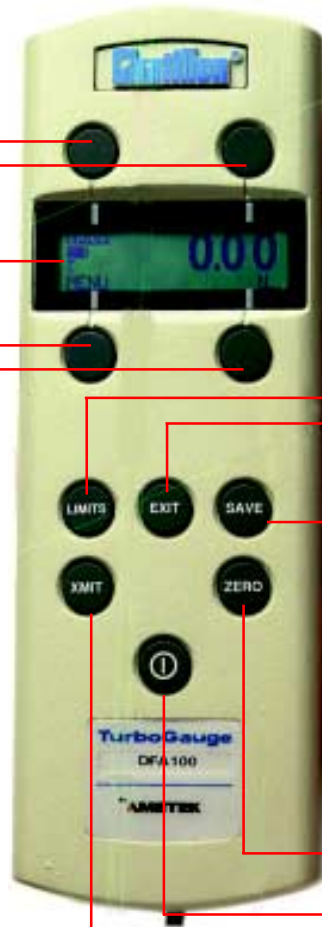

TRANSMIT... BUZZER...
HI LIM... LO LIM...

Function Key F1

Function Key F2

Function Key F3

Function Key F4

LIMITS button allows you to transmit signals to control test stand motion (F1). Key F2 allows you to activate or deactivate the limits buzzer, which sounds when the force exceeds the limits set. Both high and low limits may be set (F3, F4), allowing you to stop test stand motion at predetermined loads or to cycle between set points (CHATILLON® Model TCD test stands only). Limits guard against load cell damage.

EXIT button moves you back to prior screen in menu.

NORM... 0.1256 LB
MENU...

NORM... BATCH 01 #001 NB...
REVIEW... 00% LB

SAVE button takes you to "Data Save" mode, where you can save a reading to current batch or open a new batch (F2). Once data is saved, the F3 key allows you to review your saved data. The F4 key lets you change reading units to lb, Kg, N, oz and g. Up to 1,000 different time-stamped readings may be saved, in as many as 99 batches.

ZERO button returns current data reading in window to "0".

ON/OFF key saves all gauge setting each time the gauge is turned off.

XMIT button transmits current reading or batch via the gauge's RS-232 port or sends it to a Mitutoyo data collector.

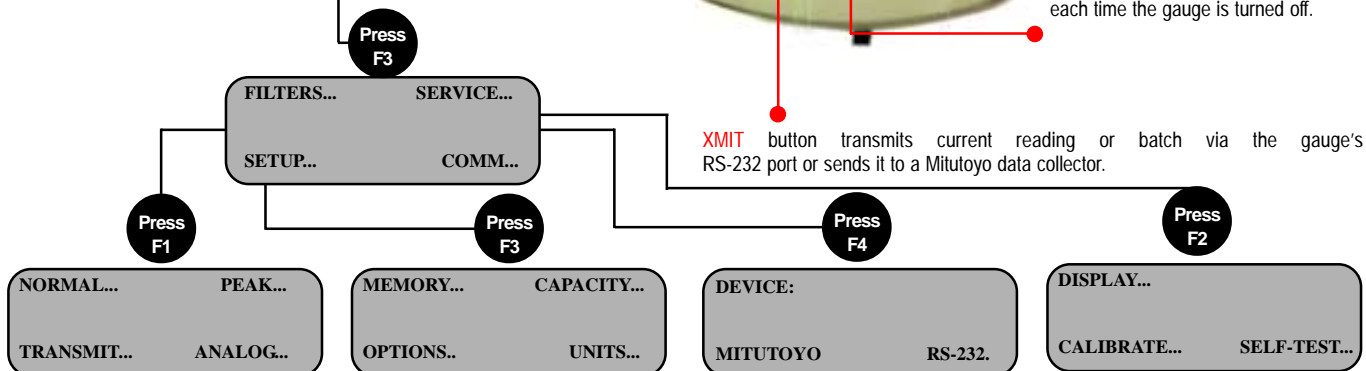

FILTERS MENU lets you set the sampling rate for four different streams of data -- normal force reading, peak force reading, RS-232 transmission and analog output. (See table on opposite page.) With each stream, you can regulate and change the data rate to match your needs. The resulting data flow is averaged from all of the data points taken at the the gauge's inherent sampling rate of 10,000 samples per second. The result is a distillation of data that still reflects the extraordinarily high collection rate of the gauge.

EXAMPLE SUBSCREEN
(for peak filter rate)

PEAK: INCREASE
0.1256

SETUP MENU allows you to set the time and date under "Memory" (F1) and to activate various options (F3), such as auto shutdown, sign, and print options. The capacity menu (F2) is only available for the Remote Non-Dedicated Gauges and allows the gauge to be set for proper maximum load. The Units menu (F4) allows you to "lock in" the desired units of measurement, keeping them from being changed accidentally.

COMMUNICATIONS MENU is for selecting Mitutoyo or RS-232 output. This menu lets you quickly and easily set the parameters for RS-232 communications, such as from the gauge to a digital test stand or to a remote computer. Settings include stop bit length, baud rate, and parity, as well as whether units are to be included with the transmission.

EXAMPLE SUBSCREEN
(for baud rate):

BAUD INCREASE
0.1256
OK 19200 DECREASE

SERVICE MENU allows you to adjust the display contrast (F1) lighter or darker for display angle and light conditions. You can also calibrate the gauge (F3) using standard weights, as well as troubleshoot gauge problems with a self-test setting (F4). The latter is a highly useful tool for AMETEK service technicians, allowing them to work with you over the telephone to check out your gauge. It includes tests for proper keypad function and possible load cell damage.

SPECIFICATIONS

Accuracies

$\pm 0.15\%$ of Full Scale \pm Least Significant Count

Data Storage

Stores up to 1000 data values in as many as 99 different user-defined batches

Sampling Rate

10,000 samples per second. User-adjustable Filters

Deflection

0.010-inch (0.254mm) maximum for full load

Safe Overload

Gauge will display "OVERLOAD" when the force applied exceeds 116% of the gauge capacity.

Maximum Overload

150% of gauge capacity. Load cell deformation may occur when overload exceeds 150%. Note: Gauge reading will not exceed 121%. If you feel the gauge may have exceeded the gauge capacity, contact your local AMETEK Representative.

Tare Capacity

10% in order to utilize full scale (in lb Mode); can tare more than 10%, however, user may not have the use of gauge's full scale capacity during testing

Analog Output

0 to ± 2.0 Vdc full scale, accurate to ± 0.015 V

Digital Input/Output

+5V signal when High or Low setpoint is reached

Display

32 x 122 pixel LCD dot matrix Adjustable contrast

Display Refresh

250mS refresh in Normal and Peak modes

Keypad

Six dedicated function keys with labels: LIMITS, EXIT, SAVE, XMIT, ZERO and ON/OFF.

Four dynamic function keys which change based on display context.

Keys feature audible and tactile feedback.

Data Collect Mode

100 samples per second

Communications

Bi-directional RS-232 serial data communications, transmits up to 100 data points per second. User-selectable baud rates from 300 to 115,200. MITUTOYO output.

Power

Rechargeable 8-hour NiCad battery, or continuous AC operation using battery charger supplied (110Vac or 220Vac)

Battery Life

8-10 hours of continuous operation between charges

Temperature Range

40° to 110°F (5° to 45°C)

Temperature Stability

0.03% per °F

ORDERING INFORMATION

Model	Capacity x Resolution
DFA-R-250G	8 oz x 0.004 oz 250 g x 0.1 g 2.5 N x 0.001 N
DFA-R-2	32 oz X 0.004 oz 2 lb x 0.0002 lb 1000 g x 0.1 g 1 kg x 0.0001 kg 10 N x 0.001 N
DFA-R-10	160 oz x 0.02 oz 10 lb x 0.001 lb 5000 g x 0.5 g 5 kg x 0.0005 kg 50 N x 0.0005 N
DFA-R-50	800 oz x 0.1 oz 50 lb x 0.005 lb 20000 g x 2 g 25 kg x 0.002 kg 250 N x 0.02 N
DFA-R-100	1600 oz x 0.2 oz 100 lb x 0.01 lb 50000 g x 5 g 50 kg x 0.005 kg 500 N x 0.05 N
DFA-R-200	3200 oz x 0.04 oz 200 lb x 0.02 lb 100 kg x 0.01 kg 1000 N x 0.1 N
DFA-R-500	8000 oz x 1 oz 500 lb x 0.05 lb 200 kg x 0.02 kg 2000 N x 0.2 N
DFA-R-1000	16000 oz x 2 oz 1000 lb x 0.1 lb 500 kg x 0.05 kg 5000 N x 0.5 N

Note: Please add "-220V" after the Model number if you require 220V power and operation.

GAUGE ADAPTERS

Adapters	Capacity	Availability	Part No.	Notes
Chisel Point, #10-32	100 lbf (500 N)	Optional	SPK-FMG-008A	
Chisel Point, 5/16-18	500 lbf (2.5 kN)	Optional	SPK-FMG-008B	
Point Adapter, #10-32	100 lbf (500 N)	Optional	SPK-FMG-009A	
Point Adapter, 5/16-18	500 lbf (2.5 kN)	Optional	SPK-FMG-009B	
Notch Adapter, #10-32	100 lbf (500 N)	Optional	SPK-FMG-010A	
Notch Adapter, 5/16-18	100 lbf (500 N)	Optional	NC000721	5/8 inch (15mm) notch size
Notch Adapter, 5/16-18	500 lbf (2.5 kN)	Optional	SPK-FMG-010B	
Notch Adapter, 5/16-18	500 lbf (2.5 kN)	Optional	NC000725	1.0-inch (25mm) notch size
Flat Adapter, #10-32	100 lbf (500 N)	Optional	SPK-FMG-011A	
Flat Adapter, 5/16-18	500 lbf (2.5 kN)	Optional	SPK-FMG-011B	
Flat Disc, 5/16-18		Optional	NC000751-1	3.25 x 0.5 inch (83 x 12mm)
Flat Disc, 5/16-18		Optional	NC000751-2	3.25 x 0.25 inch (83 x 6mm)
Rectangular Fixture, 5/16-18		Optional	NC000730-1	3.5 inch (89mm) diameter
Rectangular Fixture, 5/16-18		Optional	NC000738-1	0.75 inch (19mm) diameter
Hook, #10-32	50 lbf (225 N)	Optional	SPK-FMG-012A	
Hook, #10-32	100 lbf (500 N)	Optional	SPK-FMG-012B	
Hook, Swivel, #10-32	20 lbf (112 N)	Optional	ML3867	
Hook, Swivel, #10-32	100 lbf (500 N)	Optional	ML3850	
Hook, 5/16-18	500 lbf (2.5 kN)	Optional	SPK-FMG-012C	
Hook, Swivel, 5/16-18	500 lbf (2.5 kN)	Optional	ML3868	
Hook, with Clasp, 5/16-18	500 lbf (2.5 kN)	Optional	NC002500	
Extension Rod, #10-32		Optional	SPK-FMG-013A	
Extension Rod, 5/16-18		Optional	SPK-FMG-013B	
Adapter, #10-32F to 5/16-18M		Optional	P-10020	Required for 5/16 Fixtures
Coupling, #10-32 to 6M		Optional	NC002652	For metric probes/grips



Chisel Point



Point Adapter



Notch Adapter



Flat Adapter



Hook

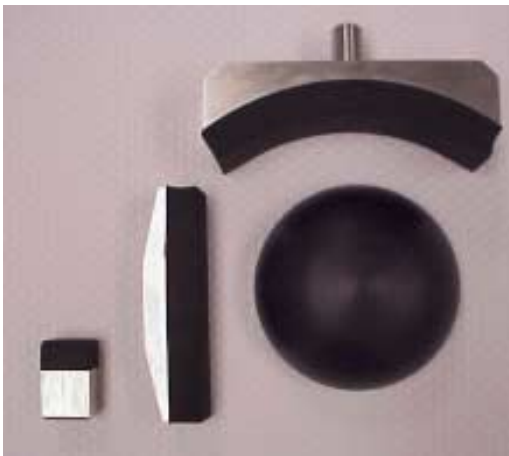

Specialty Fixtures for Ergonomics

The DFGS Series can be equipped with specialty fixture for ergonomic testing, muscle strength testing and job task analysis applications. Shown are various fixtures including rectangular fixtures and flat discs.

STANDARD ACCESSORIES

Accessories	Availability	Part No.	Notes
Protective Carrying Case	Standard	SPK-FMG-073	
Battery Charger, 115V	Standard	SPK-FMG-069A	Standard with 115V models
Battery Charger, 220V	Standard	SPK-FMG-069B	Standard with 220V models
Hex Key, 7/64-inch	Standard	SPK-FMG-015	
Operators' Manual	Standard	SPK-DFA-081	
Flash Memory Upgrade Kit	Optional	E80-715	

TEST STAND GAUGE ADAPTER KITS

Test Stand Type	Availability	Part No.	Notes
LTS Series	Optional	NC000300	
LTC Series	Optional	NC000300	
HTC Series	Optional	NC000225	
TT Tester	N/A	N/A	Not Compatible
LTCM-6 Series	Optional	NC000300	
TCM201 Series	Optional	NC000300	
TCD200 Series	Optional	NC000300	
LFPLUS Series	Optional	SPK/LFM/0001	
LRX Series	N/A	N/A	Not Compatible
LRXPLUS Series	N/A	N/A	Not Compatible
LR5KPLUS Series	N/A	N/A	Not Compatible

GAUGE APPLICATION SOFTWARE

Software	Availability	Part No.	Notes
NEXYGEN GAUGE Software (Single User)	Optional	40/0739	Single User License
NEXYGEN GAUGE Software (5 Pack)	Optional	40/0739/5	5 User License
NEXYGEN GAUGE Software (10 Pack)	Optional	40/0739/10	10 User License

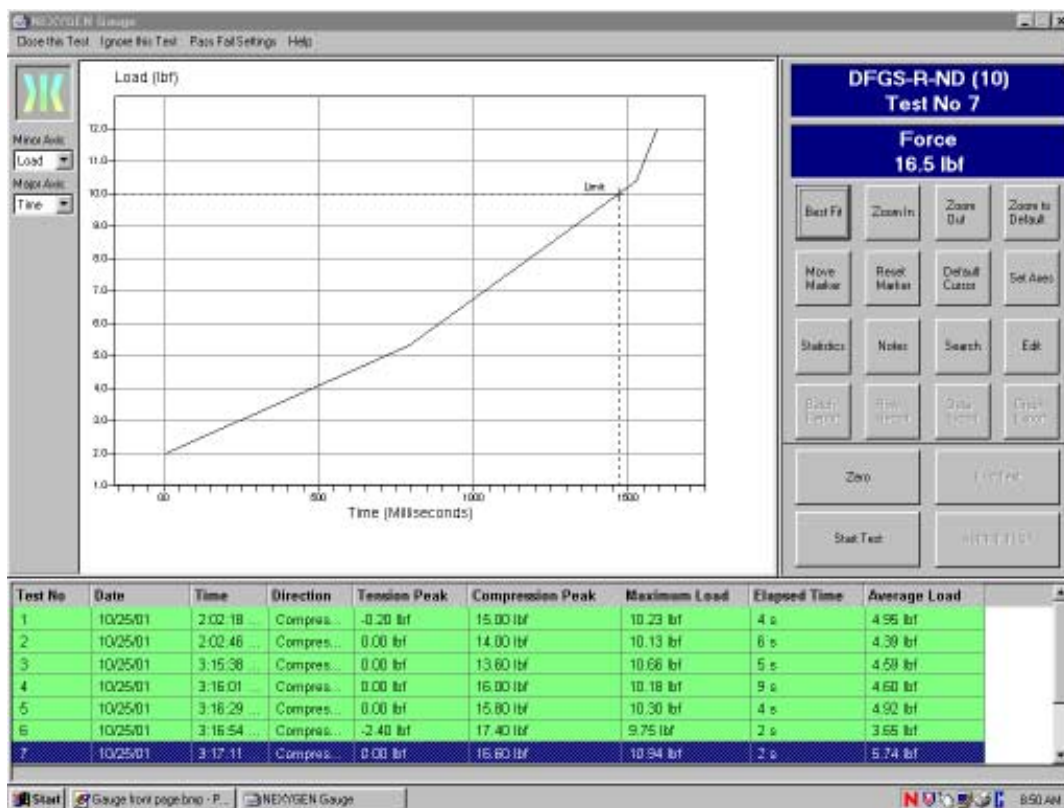

NEXYGEN GAUGE software allows you to collect load measurements from your force gauge and display and analyze results information in both tabular and graphical formats. You can automatically create reports in WORD or EXCEL and define pass/fail conditions. You can change the size of your graph, overlay graphs, add notations, etc.

INTERFACE CABLES

Interface Cables	Availability	Part No.	Notes
Personal Computer, 25-pin D, 6ft (2m)	Optional	NC000652	
Personal Computer, 25-pin D, 10ft (3m)	Optional	NC000652-1	
Personal Computer, 25-pin D, 20ft (7m)	Optional	NC000652-3	
Personal Computer, 9-pin D, 6ft (2m)	Optional	NC000850-1	Require when using NEXYGEN
Personal Computer, 9-pin D, 10ft (3m)	Optional	NC000850-2	Require when using NEXYGEN
MITUTOYO, 10-pin	Optional	NC000654	
MITUTOYO, RS232	Optional	NC000697	
TCM201, 9-pin D	Optional	ENC0125	
TCD200, 9-pin D	Optional	NC000647	

DIMENSIONS- DFA-R Series

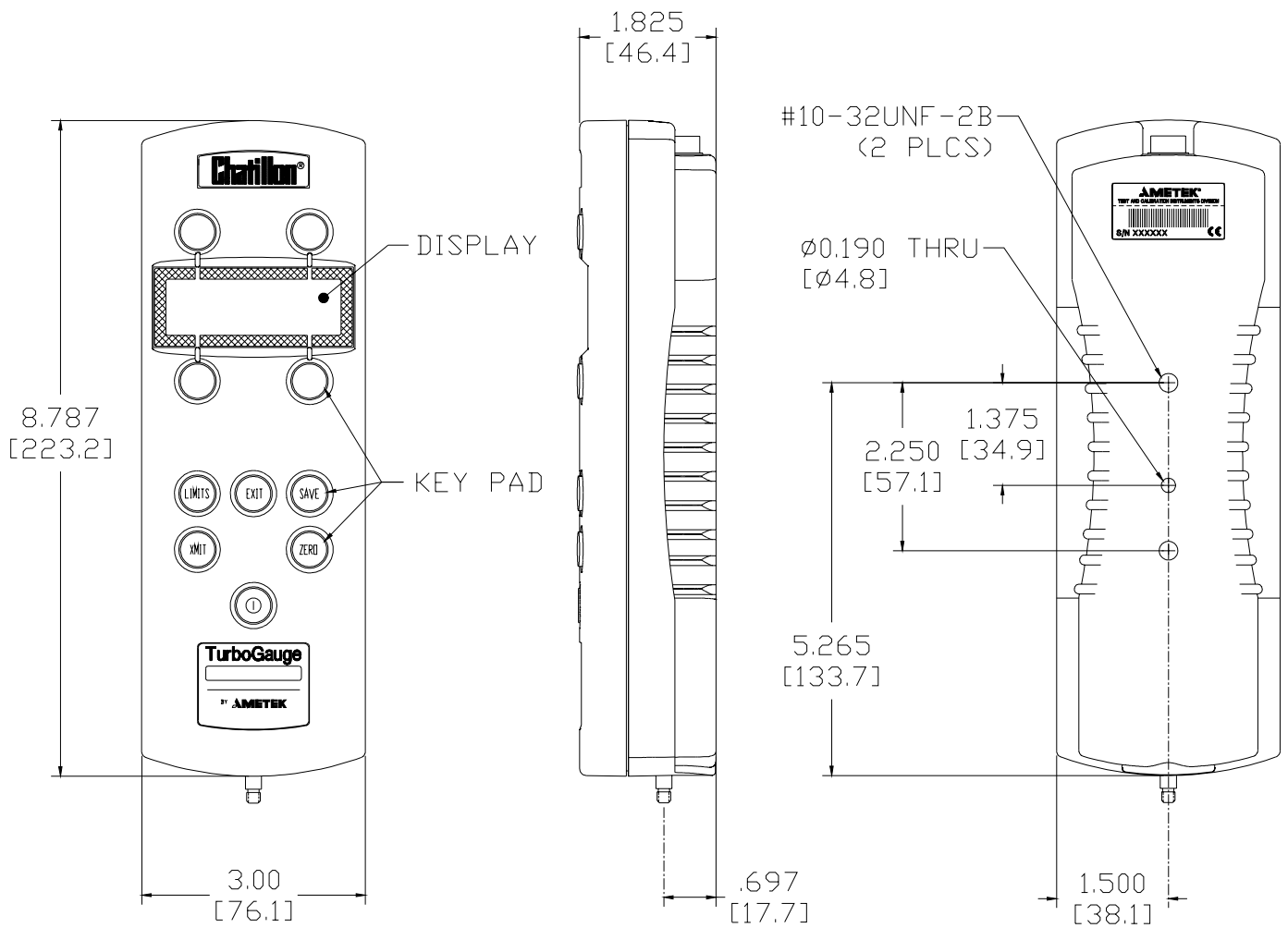

E96-188

AMETEK

TEST AND CALIBRATION INSTRUMENTS

Americas
 AMETEK TCI Division
 8600 Somerset Drive
 Largo, Florida 33773
 United States of America
 Tel +1-727-536-7831
 Tel +1-800-527-9999
 Fax +1-727-539-6882
 Email chatillon.fl-har@ametek.com

United Kingdom
 AMETEK Lloyd Instruments Ltd.
 Forum House, 12 Barnes Wallis Rd
 Segensworth East
 Fareham
 Hampshire PO15 5TT
 United Kingdom
 Tel +44-0-1489-574221
 Fax +44-0-1489-885118
 Email general@lloyd-instruments.co.uk

France
 AMETEK Lloyd Instruments SA
 3 avenue des Coudriers
 Zone d'Activite de l'Observatoire
 78180 Montigny-Le-Bretonneux
 France
 Tel +33-1-3057-4774
 Fax +33-1-3057-5033
 Email general@lloyd-instruments.co.uk

Germany
 AMETEK Precision Instruments
 Europe GmbH
 Rudolf-Diesel-Strasse 16
 D-40670 Meerbusch
 Germany
 Tel +49-0-2159-9136-70
 Fax +49-0-2159-9136-80
 Email apie@ametek.de

Singapore
 AMETEK Singapore Pvt. Ltd.
 10 Ang Mo Kio Street 65
 #05-12 Techpoint
 Singapore 569059
 Tel +65-484-2388
 Fax +65-481-6588
 Email aspl@ametek.com.sg

Australia
 AMETEK Lloyd Instruments
 No. 7 Sherwood Place
 Alexander Heights
 6064 Perth
 Australia
 Tel +61-8-9343-5725
 Fax +61-8-9343-5723
 Email general@lloyd-instruments.co.uk

DIMENSIONS- REMOTE Series Loadcells

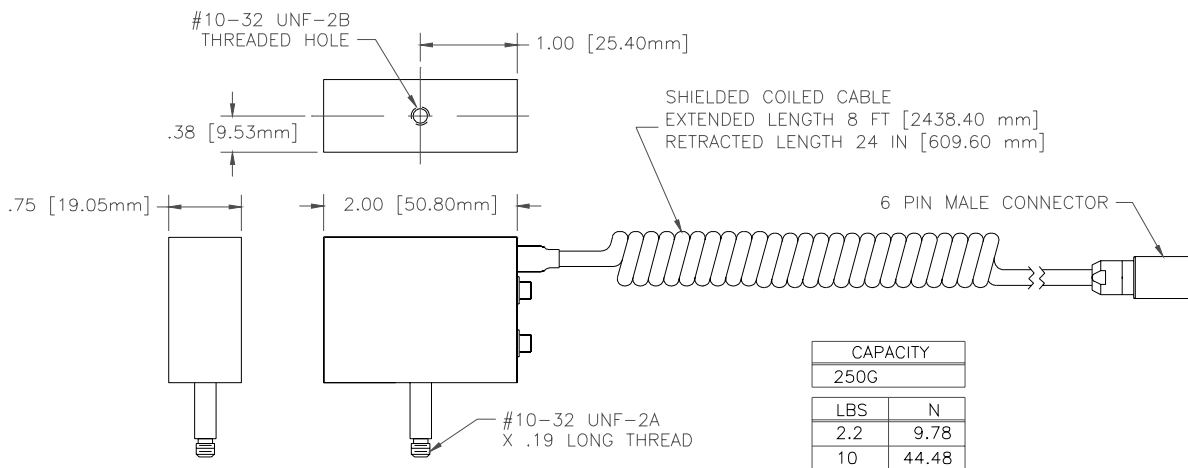

CAPACITY	
250G	
LBS	N
2.2	9.78
10	44.48

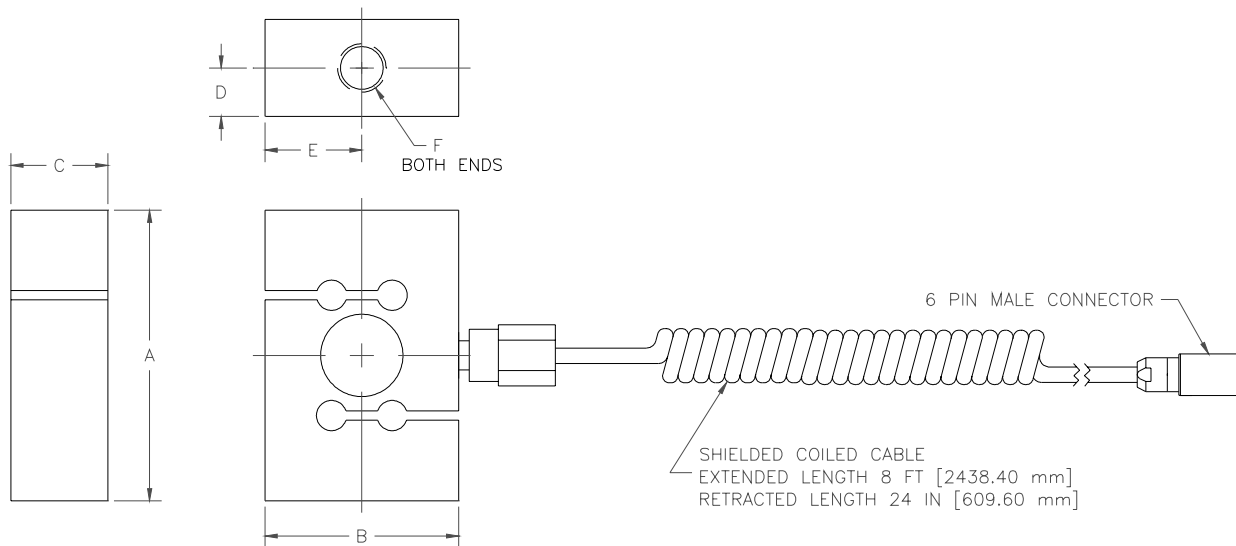

CAPACITY		A		B		C		D		E		F
LBS	N	IN	mm	IN	mm	IN	mm	IN	mm	IN	mm	THREAD
50	222.4	2.50	63.50	2.00	50.80	.63	16.00	.313	7.95	1.00	25.40	1/4-28
100	444.8	2.50	63.50	2.00	50.80	.63	16.00	.313	7.95	1.00	25.40	1/4-28
200	889.6	2.50	63.50	2.00	50.80	.63	16.00	.313	7.95	1.00	25.40	1/4-28
500	2224.1	3.00	76.20	2.00	50.80	1.00	25.40	.500	12.70	1.00	25.40	1/2-20
1,000	4448.2	3.00	76.20	2.00	50.80	1.00	25.40	.500	12.70	1.00	25.40	1/2-20
2,000	8896.4	3.00	76.20	2.00	50.80	1.00	25.40	.500	12.70	1.00	25.40	1/2-20
5,000	22241.0	4.25	107.95	3.00	76.20	1.00	25.40	.500	12.70	1.50	38.10	3/4-16
10,000	44482.0	4.75	120.65	3.50	88.90	1.00	25.40	.500	12.70	1.75	44.45	3/4-16

DFGS-R/AF4
FILE NAME: E96-316.DWG
PAGE 2 OF 2

AMETEK TEST AND CALIBRATION INSTRUMENTS

Americas
AMETEK TCI Division
8600 Somerset Drive
Largo, Florida 33773
United States of America
Tel +1-727-536-7831
Tel +1-800-527-9999
Fax +1-727-539-6882
Email chatillon.fl-lar@ametek.com

United Kingdom
AMETEK Lloyd Instruments Ltd.
Forum House, 12 Barnes Wallis Rd
Segensworth East
Fareham
Hampshire PO15 5TT
United Kingdom
Tel +44-0-1489-574221
Fax +44-0-1489-885118
Email general@lloyd-instruments.co.uk

France
AMETEK Lloyd Instruments SA
3 avenue des Coudriers
Zone d'Activite de l'Observatoire
78180 Montigny-Le-Bretonneux
France
Tel +33-1-3057-4774
Fax +33-1-3057-5033
Email general@lloyd-instruments.co.uk

Germany
AMETEK Precision Instruments
Europe GmbH
Rudolf-Diesel-Strasse 16
D-40670 Meerbusch
Germany
Tel +49-0-2159-9136-70
Fax +49-0-2159-9136-80
Email apie@ametek.de

Singapore
AMETEK Singapore Pvt. Ltd.
10 Ang Mo Kio Street 65
#05-12 Techpoint
Singapore 569059
Tel +65-484-2388
Fax +65-481-6588
Email aspl@ametek.com.sg

Australia
AMETEK Lloyd Instruments
No. 7 Sherwood Place
Alexander Heights
6064 Perth
Australia
Tel +61-8-9343-5725
Fax +61-8-9343-5723
Email general@lloyd-instruments.co.uk